

LASER TRANSMITTER WITH 280 Hz TRANSISTOR OSC.:

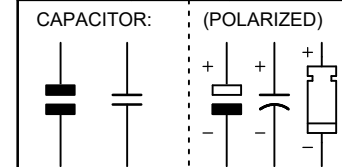

LDR RECEIVER:

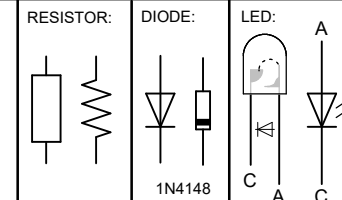
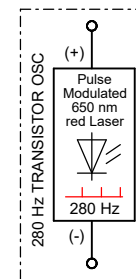
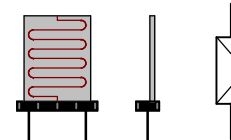

TRANSISTOR

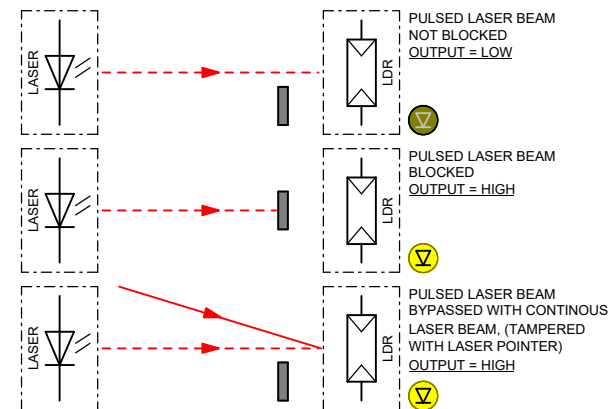
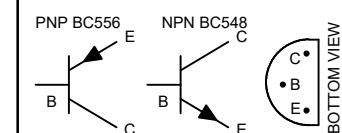

CAUTION

LASER RADIATION

DO NOT STARE INTO BEAM

LASER PROTECTIVE EYEWEAR REQUIRED

FOR LASER TRANSMITTER DETAILS SEE: "A4 EXP BOARD LS2A-406.pdf"

FOR FULLY COMPONENT SPECS. SEE MANUFACTURER DATASHEETS

LS-2	A4	udo@elgers.com	ue-ERT20211127-04	27-NOV-2021
008	A	PULSED LASER DIODE EXPERIMENT 2A-04		