

ROVER CONSTRUCTION WITH ULTRASONIC RANGING MODULE HC-SR04 ( FOLLOW ME WITH COLLISION PROTECTION ) WIRING AND SCHEMATICS

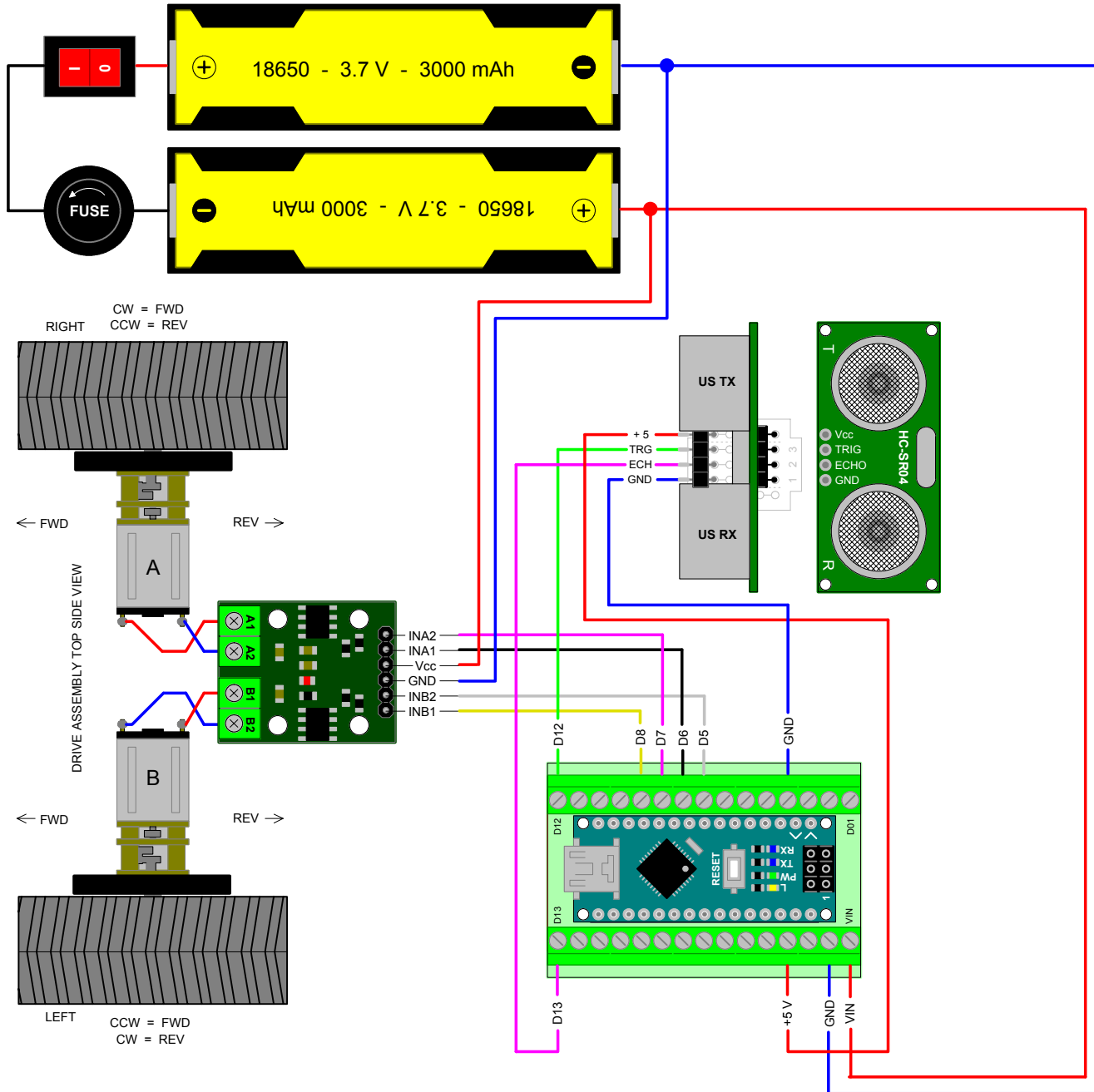

RIGHT CW = FWD CCW = REV

← FWD → REV →

DRIVE ASSEMBLY TOP SIDE VIEW

← FWD → REV →

LEFT CCW = FWD CW = REV

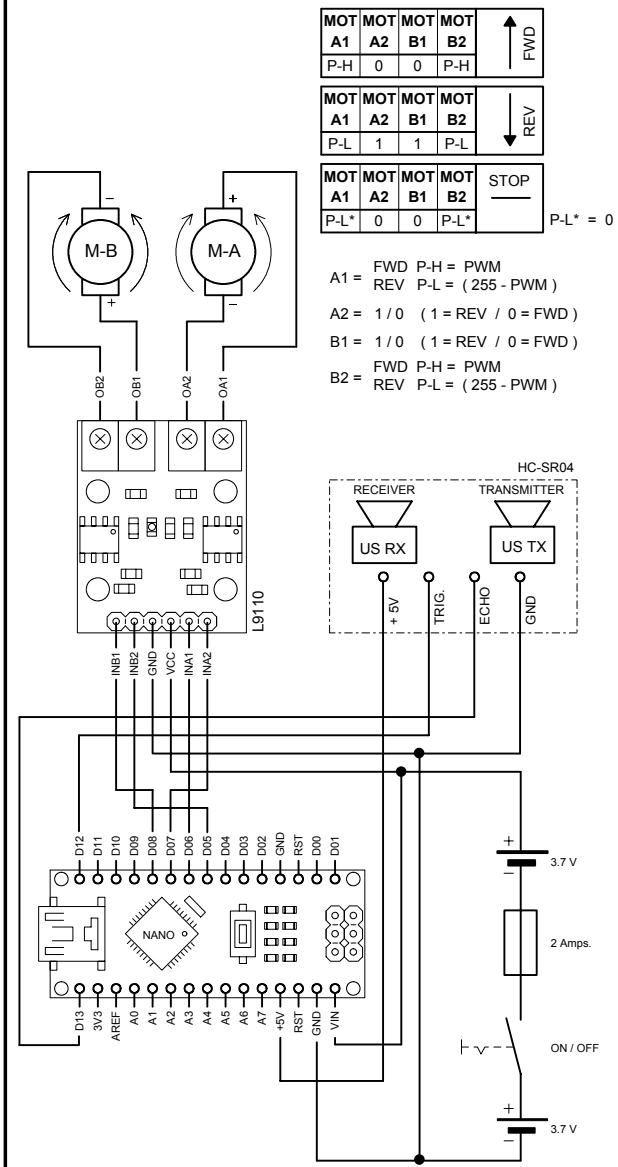

FIGURES ARE APPROXIMATELY, DUE TO COMPONENT TOLERANCES! FOR FULLY COMPONENT SPECS. SEE MANUFACTURER DATASHEETS. BRANDS AND NAMES ARE MENTIONED PURELY FOR INFORMATION PURPOSES.

AR-8 / 1	A4	udo@elgers.com	ue-ERT20240627-28
033	A	MINI-ROVER WITH TOTEMMAKER COMPONENTS	